



Air Plains Services Corporation  
P.O Box 541  
Wellington, KS 67152  
Tel. 620-326-8904  
www.airplains.com

# MANDATORY SERVICE BULLETIN

Service Bulletin: APS-05-05-01

August 18, 2005

## TITLE

Addition of fuel selector stop and fuel selector plate to STC SA00052WI.

## EFFECTIVITY

**Make:** Cessna  
**Model:** 182H, 182J, 182K, 182L, 182M, 182N, 182O, 182P, 182Q and 182R.

## REASON

In the event the fuel selector handle is inadvertently placed in the "OFF" position, the aircraft's engine will run until the available fuel in the reservoir tank is depleted. This may occur during taxi sequence, during or soon after takeoff. This can result in personal injury or death. The installation of the fuel selector stop under this service bulletin will alleviate this potentially dangerous condition by permitting the free flow of fuel from the header tanks while still allowing the pilot to exercise the option of affirmatively shut off the fuel flow by using the fuel shut off valve.

## DESCRIPTION

Aircraft fuel selector valve will be installed with a tab (166) that does not allow the selector to be placed in the "OFF" position.

## COMPLIANCE

Compliance with this service bulletin is mandatory.

## APPROVAL

FAA approval has been obtained on the technical data in this publication that affects airplane type design.

## MATERIAL AVAILABILITY

Parts are available from Air Plains Services, Corp. If the installation is conducted at our facility in Wellington, KS, there will be no additional cost on the installation. Please call 1-800-752-8481 for the latest information and to schedule the service.

## INSTALLATION INSTRUCTIONS

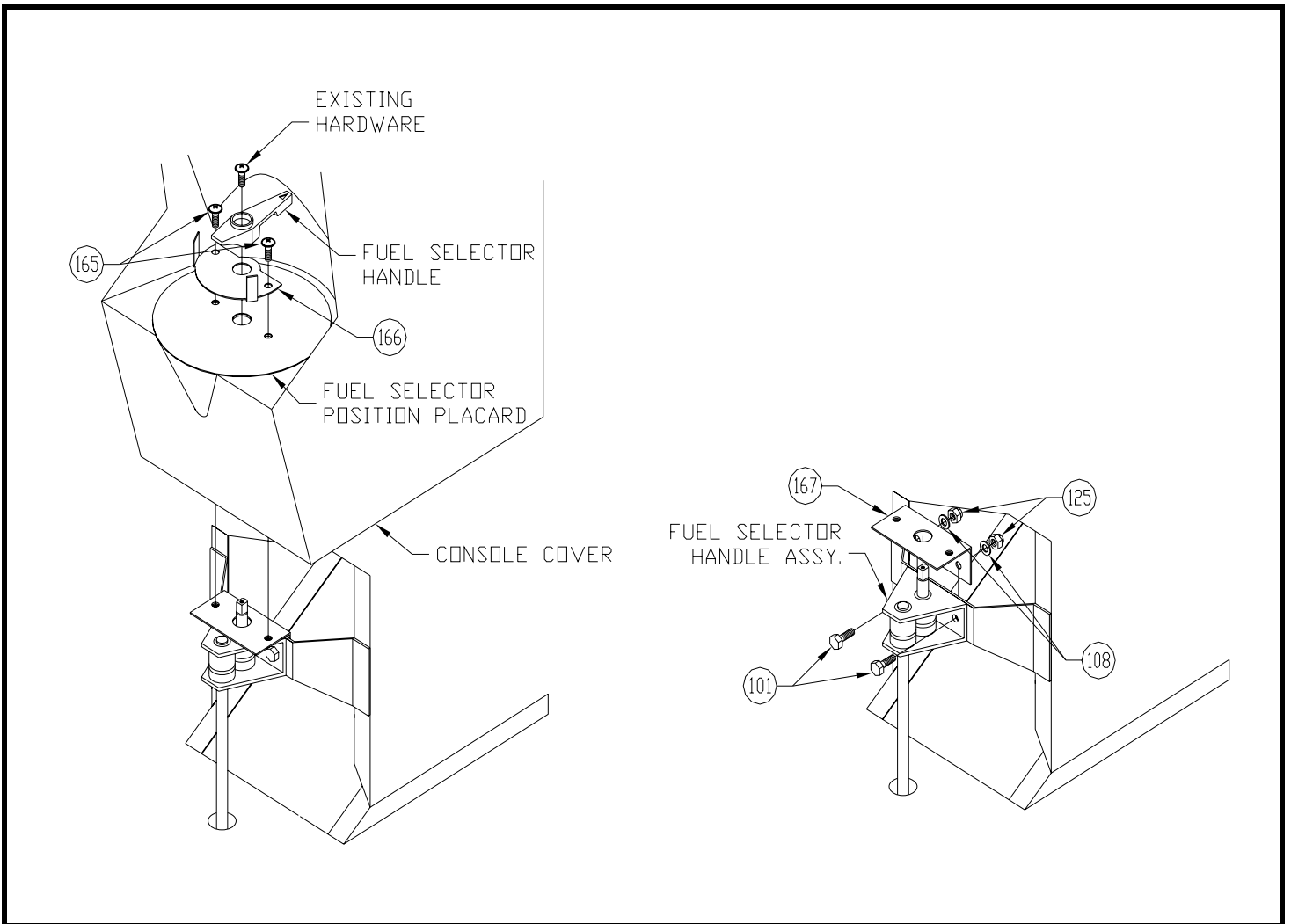

Figure 1 - Fuel Selector Stop Installation Detail

### MANPOWER

Approximately a total of 1.5 hours of manpower per installation.

### MATERIAL INFORMATION

Parts required:

Table 1 - Required parts

Reference Number	Part Number	Quantity	Description
101	AN3-4A	2	Bolt
108	AN960-10L	2	Washers
125	MS21045-3	2	Nut
165	AN525-832R7	2	Machine Screw
166	182024-201	1	Fuel Selector Stop
167	182024-202	1	Fuel Selector Plate

## INSTRUCTIONS

1. Prepare the airplane for maintenance
2. With fuel selector handle and console cover removed, discard existing AN3 bolts securing the fuel selector valve handle assembly to the console.
3. Install (167) bracket to forward side of the gear assembly. Attach bracket using (101, 108, 125) hardware.
4. Ream existing holes in fuel selector position placard and center console cover to 3/16 inches diameter.
5. Re-Install Console Cover
6. Install fuel selector position placard and (166) fuel selector stop, using (165) screws.
7. Re-install fuel selector handle.

## INCLUDED DOCUMENTS

The following documents included with this service bulletin are:

- Installation Drawing: **Drawing 182024 Sht2 Rev3 - Fuel Valve Installation**
- Installation Instructions: **STC SA00152WI – Cessna 182 Series Aircraft - 182031 Rev 4**
- Drawing List: **Drawing List 1821 -Rev 5**